

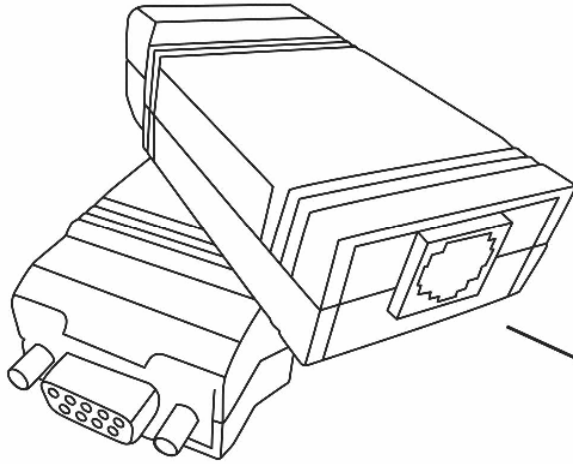

# Connections for Touch Panel Control of PerfectCue TP-2000X-PC



## RS485

— 12V —	O/W
— G —	O
— D+ —	G/W
— D- —	BL
— D- —	BL/W
— D+ —	G
— G —	B/W
— 12V —	B

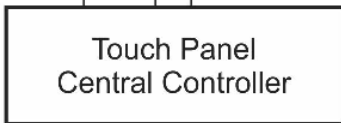
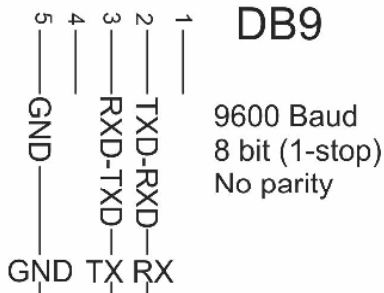

Designate selected  
com port as RS232

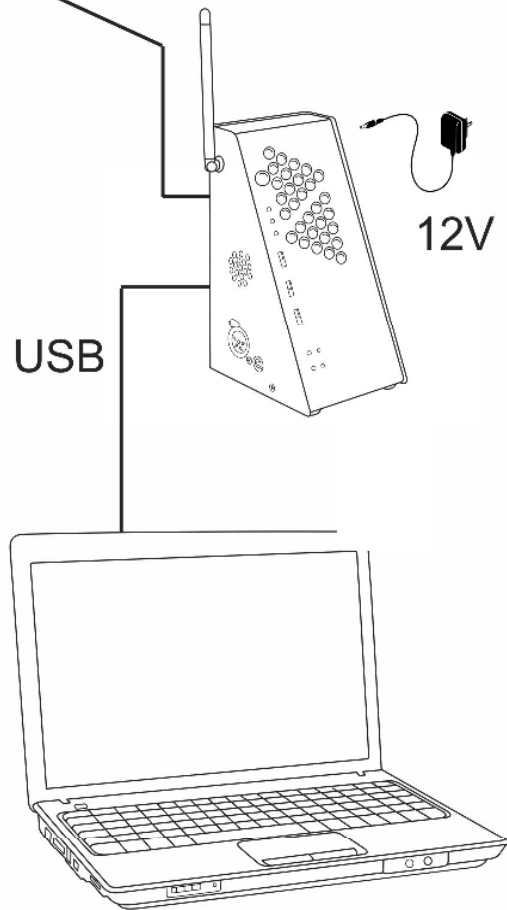
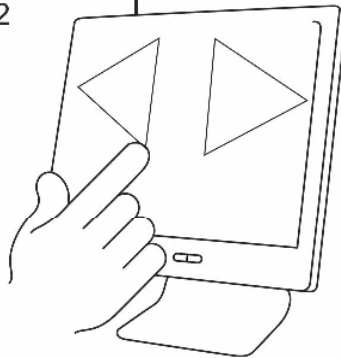

# PerfectCue<sup>®</sup> Serial Control Protocol ASCII API

These messages are formatted as follows:

>	Command String	Space	Checksum High	Checksum Low	<CR>
	Checksum				

**\*Don't forget the ">" (start of message character)**

Checksum  
Add all bytes of Command String and Space  
Use lower 2 digits  
Example:  
"FORWARD" 0x46+0x51+0x52+0x57+0x41+0x52+0x44+0x20 = 0x235  
Checksum High = 3  
Checksum Low = C  
Full Message >FORWARD<SP>35<CR>\*

\*When sending commands to PerfectCue, use carriage return delimiter "/x0D"  
(Forward slash). Return delimiter is "\x0D"

Baud Rate	9600
Data:	8-bit
Parity:	None
Stop Bit:	1

## Buttons: (to Cue Light)

Command Name	Command Message	Cue Light	Transmitter
Forward	>FORWARD<SP>35<CR>	Green Arrow	Forward Button
Reverse	>REVERSE<SP>3C<CR>	Red Arrow	Back Button
Blank on	>BLANKON<SP>25<CR>	Yellow Light	Blank Button
Blank off	>BLANKOF<SP>1D<CR>	Yellow Light Off	Blank Button

## LED Indicators: (from Cue Light)

Command Name	Command Message	Cue Light
Green Led On	>FRWLEDON<SP>81<CR>	Green Arrow On
Green Led Off	>FRWLEDOF<SP>79<CR>	Green Arrow Off
Red Led On	>RVSLEDON<SP>8D<CR>	Red Arrow On
Red Led Off	>RVSLEDOF<SP>85<CR>	Red Arrow Off
Yellow Led On	>BLKLEDON<SP>6B<CR>	Yellow LED On
Yellow Led Off	>BLKLEDOF<SP>63<CR>	Yellow LED Off